

FOCUSING SCREENS 1



Summary

- A choice of 13 interchangeable focusing screens is available. To obtain the optimum viewfinder image in every photographic situation, interchangeable focusing screens are indispensable to a true system camera.





Main Characteristics

- A full range of focusing screens insures the best image rendition with lenses of every focal length.
- With the pentaprism fixed, the screens are changed through the lens mount insuring a high degree of protection against dust and dirt.

Notes • Related Units

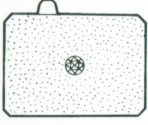
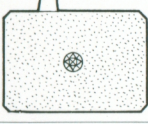
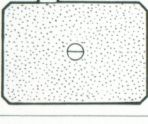
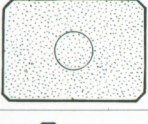
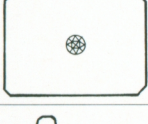
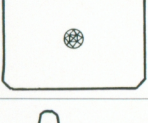
- The screen must be handled with great care. Marring the screen and mirror with fingerprints and smudge, and wiping with solvent should be avoided absolutely.
- The clear-field type focusing screens provide brighter viewfinder images. However, the meter needle on MANUAL does not give correct light readings. On AUTO the needle does not point to the precise shutter speed but correct exposures are made on the film.

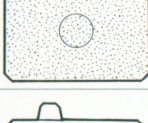
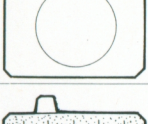
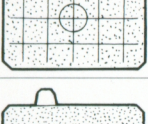
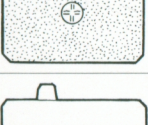
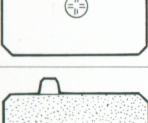
OLYMPUS

TYPE	APPLICATIONS	FOCUSING	NOTES
 <p>1 — 1 Microprism-matte type (for most lenses)</p>	Standard type focusing screen, suitable for general photography.	Fast and accurate focusing is done on the central microprism spot as well as on the surrounding matte area. The subject is in focus when the jagged pattern of the microprism spot disappears and the spot becomes crisp and clear.	When a lens with a maximum speed of F5.6 or slower is used, the microprism darkens and the focusing must be made on the matte area. The meter needle gives correct light readings.
 <p>1 — 2 Microprism-matte type (for standard & telephoto lenses)</p>	Suitable for general photography in conjunction with a standard or telephoto lens.	Focusing is done on the microprism spot as well as on the matte area.	When a lens with a maximum speed of F8 or slower is used, the microprism spot darkens—in this case, make-use of the matte area which is ground comparatively rough for easy focusing. The meter needle gives correct light readings.
 <p>1 — 3 Split image-matte type (for most lenses)</p>	Suitable for general photography ensuring critical focusing, and ideal for photographers who prefer the split-field and coincidence type focusing; particularly advantageous when taking a subject with vertical lines.	Focusing is done easily by aligning the split lines.	When a lens with a maximum speed of F5.6 or slower is used, the prism darkens. The meter needle gives correct light readings.
 <p>1 — 4 All matte type (for most lenses)</p>	Suitable for general photography and ideal for photographers who prefer a clear-cut view field free from microprism or split prism and for those who are accustomed to focus using matte area. Also suitable for super telephotography as well as close-up photography in conjunction with macro lenses and Auto Bellows.	For easy focusing the matte surface is ground rough. The subject is in focus when the image is sharp.	The meter needle gives correct light readings.
 <p>1 — 5 Microprism-clear field type (for wide angle & standard lenses)</p>	This transparent screen provides an exceptionally bright finder image. Highly suitable for snapshots using wide angle and standard lenses.	The subject is in focus when the microprism becomes crisp and clear.	The lack of a matte surface means depth-of-field effects cannot be ascertained. The meter needle does not give correct light readings, because its movement varies depending on the lenses used.
 <p>1 — 6 Microprism-clear field type (for standard & telephoto lenses)</p>	This screen is compatible with standard and telephoto lenses and provides an extremely bright finder image.	Focusing is done on the microprism spot.	The lack of a matte surface means depth-of-field effects cannot be ascertained. The meter needle does not give correct light readings.
 <p>1 — 7 Microprism-clear field type (for super telephoto lenses)</p>	Developed primarily for use with super telephoto lenses, this clear field screen provides an extremely bright finder image. The microprism spot remains bright even with a lens whose maximum speed is F11, so that this screen is ideal for use with super telephoto lenses with slow lens speeds.	Focusing is done on the microprism spot.	The lack of a matte surface means depth-of-field effects cannot be ascertained and the meter needle does not give correct light readings.
 <p>1 — 8 All matte type (for super telephoto lenses & astronomical telescopes)</p>	This screen is ideal for use with super telephoto lenses of 300mm or more in focal length, or for astrophotography.	The extreme fineness of the matte surface permits outstanding field definition.	More accurate focusing may be achieved by the use of the Varimagni Finder. When used with astronomical telescopes, bright images of celestial bodies are obtained both in direct objective and indirect magnified astrophotography. The meter needle gives correct light readings.
 <p>1 — 9 Clear field type (for endoscopic photography)</p>	Designed especially for use with Olympus endoscopes. The transparent condenser type screen has a central 23-mm diam. convex surface and no surrounding fresnel lens.	Requires no focusing when the OM-1 is attached to the endoscope by means of the OM Endoscope Adapter.	Auto-exposure is made by Olympus light supply linked to the endoscope.
 <p>1 — 10 Checker-matte type (for shift lens)</p>	This screen was specially designed for use with the Zuiko Shift Lens. The reticule engraved on the all-matte ground screen (the same as on the 1-4) is used for vertical and horizontal picture alignment in architectural and composite panoramic photography. The screen is also suitable for general photography, super-telephotography, and close-up/macro photography in conjunction with the macro lenses and auto bellows.	Focusing is done on the matte area.	The meter needle gives correct light readings.
 <p>1 — 11 Cross hairs-matte type (for close-up & macro photography)</p>	This screen has a cross hairs spot surrounded by a finely ground matte area and is highly advantageous for close-up and macro photography in conjunction with Auto Bellows and extension tubes.	For focusing in low magnification close-up photography, use the matte area, and in greater than life size macro photography use the double cross hairs in the same way as with the 1-12 Focusing Screen.	The meter needle gives correct light readings, but depending on the condition of the specimen, the reading must be compensated for (e.g., black dots against white background).
 <p>1 — 12 Cross hairs-clear field type (for photomicrography & greater than life size macro photography)</p>	The transparent screen offers the photographer focusing with an unusually bright finder image. Ideal for macro photography of 1:1 or over, and for photomicrography.	To focus, first correct your diopter using a dioptic correction lens or Varimagni Finder so that each line of the double cross hairs can be seen clearly and separately. Then bring the specimen into focus.	The meter needle gives correct light readings, but depending on the specimen's conditions, the reading must be compensated for.
 <p>1 — 13 Microprism/split image-matte type (for most lenses)</p>	Most suitable for normal photography, this screen assures pinpoint focusing. The central split-image rangefinder is encircled by a microprism collar. Since the outer area has a matte surface, the screen can be used in the same way as the standard 1-1 and 1-3 screens.	Align the split vertical lines of the subject image, or focus on the microprism or matte area.	When a lens with a maximum speed of F5.6 or slower is used, the prism darkens and focusing must be made on the matte area. The meter needle gives correct light readings.

● Lens/Focusing Screen Combination Table

LENSES		TYPES	1-1	1-2	1-3	1-4	1-5	1-6	1-7	1-8	1-9	1-10	1-11	1-12	1-13
FISHEYE	ZUIKO FISHEYE	8mm F2.8	Compatible	Compatible	Compatible	Compatible	Compatible					Compatible			Compatible
	ZUIKO FISHEYE	16mm F3.5		*			Compatible								
SUPER WIDE	ZUIKO MC	18mm F3.5		*			Compatible								
	ZUIKO	21mm F3.5		*			Compatible								
	ZUIKO MC	24mm F2		*			Compatible								
	ZUIKO	24mm F2.8		*			Compatible								
WIDE	ZUIKO MC	28mm F2		*			Compatible								
	ZUIKO	28mm F3.5		*											
	ZUIKO MC	35mm F2					Compatible								
	ZUIKO	35mm F2.8					Compatible								
	ZUIKO SHIFT	35mm F2.8	*	*	*										*
STANDARD	ZUIKO	55mm F1.2					Compatible	Compatible							
	ZUIKO	50mm F1.4					Compatible	Compatible							
	ZUIKO	50mm F1.8					Compatible	Compatible							
	ZUIKO MACRO	50mm F3.5					Compatible								
ZOOM	ZUIKO ZOOM	75-150mm F4					Compatible	Compatible							
TELEPHOTO	ZUIKO	85mm F2					Compatible	Compatible							
	ZUIKO	100mm F2.8					Compatible	Compatible							
	ZUIKO	135mm F2.8					Compatible	Compatible							
	ZUIKO	135mm F3.5					Compatible	Compatible							
	ZUIKO	200mm F4						Compatible	Compatible						
	ZUIKO	200mm F5						Compatible	Compatible						
SUPER TELEPHOTO	ZUIKO	300mm F4.5						Compatible	Compatible						
	ZUIKO	400mm F6.3	*		*			Compatible	Compatible						*
	ZUIKO	600mm F6.5	*		*			Compatible	Compatible						*
	ZUIKO	1000mm F11	*	*	*			Compatible	Compatible						*
SPECIAL (Used with Auto Bellows)	ZUIKO MACRO	20mm F3.5	*	*	*	*						*			*
	ZUIKO MACRO	38mm F3.5	*	*	*										*
	ZUIKO 1:1 MACRO	80mm F4	*	*	*										*

 **Compatible:** The meter needle gives correct light readings. In combination marked with *, microprism, split-image prism and edge of finder darken.

 **Compatible:** Provides a brighter finder image and easy focusing. The built-in exposure meter of the OM-1 and OM-2 (on MANUAL) cannot be used. On AUTO, the OM-2 makes correct exposures but the meter needle does not give correct shutter speeds.

OM SYSTEM FOCUSING SCREENS 1

- To remove the focusing screen:
 - a) After detaching the lens from the camera body, insert the supplied special tool into the camera and push on the release catch underneath the top ledge of the mirror box towards you. This allows the screen and screen frame to drop down.
 - b) The screen can be made to drop completely down without touching it. Remove the screen from inside the camera by gripping the tipped portion between the tool's jaws.
- To install the screen, fit it in the frame and push the frame upward gently until it clicks into place.

Gently shake the camera body to make sure the screen is held securely in place.

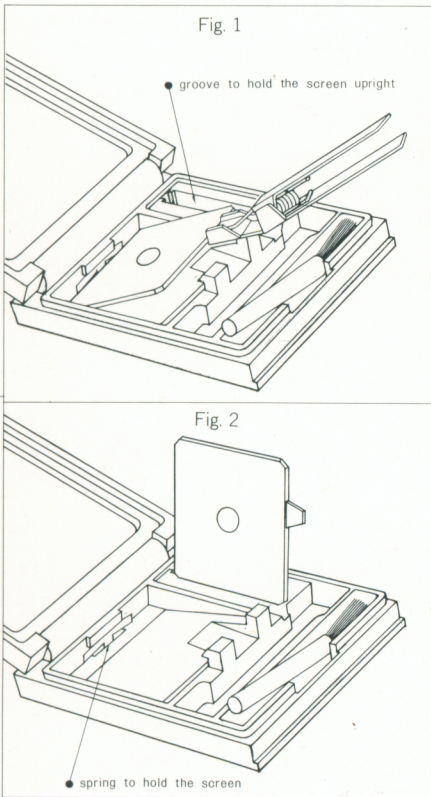

- Handling the special tool
The tab of the screen is gripped firmly by the tool as shown in Fig. 1. The groove is convenient to hold the removed screen upright to prevent its surface from getting marred (Fig. 2). (To take the tool readily out of the case, depress the jaw to lift the handle and pick it up.)
- * When storing the 1-9 in the case, put it with the convex surface facing upward to prevent it from getting scratched.