

E

OLYMPUS[®]



Auto Bellows
■ Instruction Manual

INSTRUCTION MANUAL FOR AUTO BELLOWS

CONTENTS

TO THE OWNER OF THE AUTO BELLOWS

We appreciate very much that you have acquired an Auto Bellows, a center of the versatile extension system for close-up and macrophotography.

The Auto Bellows can be used with the various units of the OM System in a wide range of applications for almost every kind of macrophotographic work from the most basic to the most demanding and complex. To make your close-ups and macrophotographs a totally creative and enjoyable art, make yourself familiar with the use of this unit and obtain optimum performance from it.

●Description of Controls	3
●Scale on the Rail	4
●Assembly	5 ~ 6
●Focusing	7
●Using the Scale	8
●Exposure on the TTL Direct Auto (OTF) Mode (OM-2)	8
●Connecting the Double Cable Release	9
●Adjustment of the Double Cable Release	10
●Manual Exposure Mode	11
●Exposure Compensation	11
●Determining the Subject Area and Choosing the Lens	12
●Reversing the Lens	13 ~ 14
●Duplication	14
●Lighting	15 ~ 16
●Use of a Varimagni Finder	16
●Close-up Tables	17 ~ 21
●Specifications	22
●Care for Use and Maintenance	22



DESCRIPTION OF CONTROLS

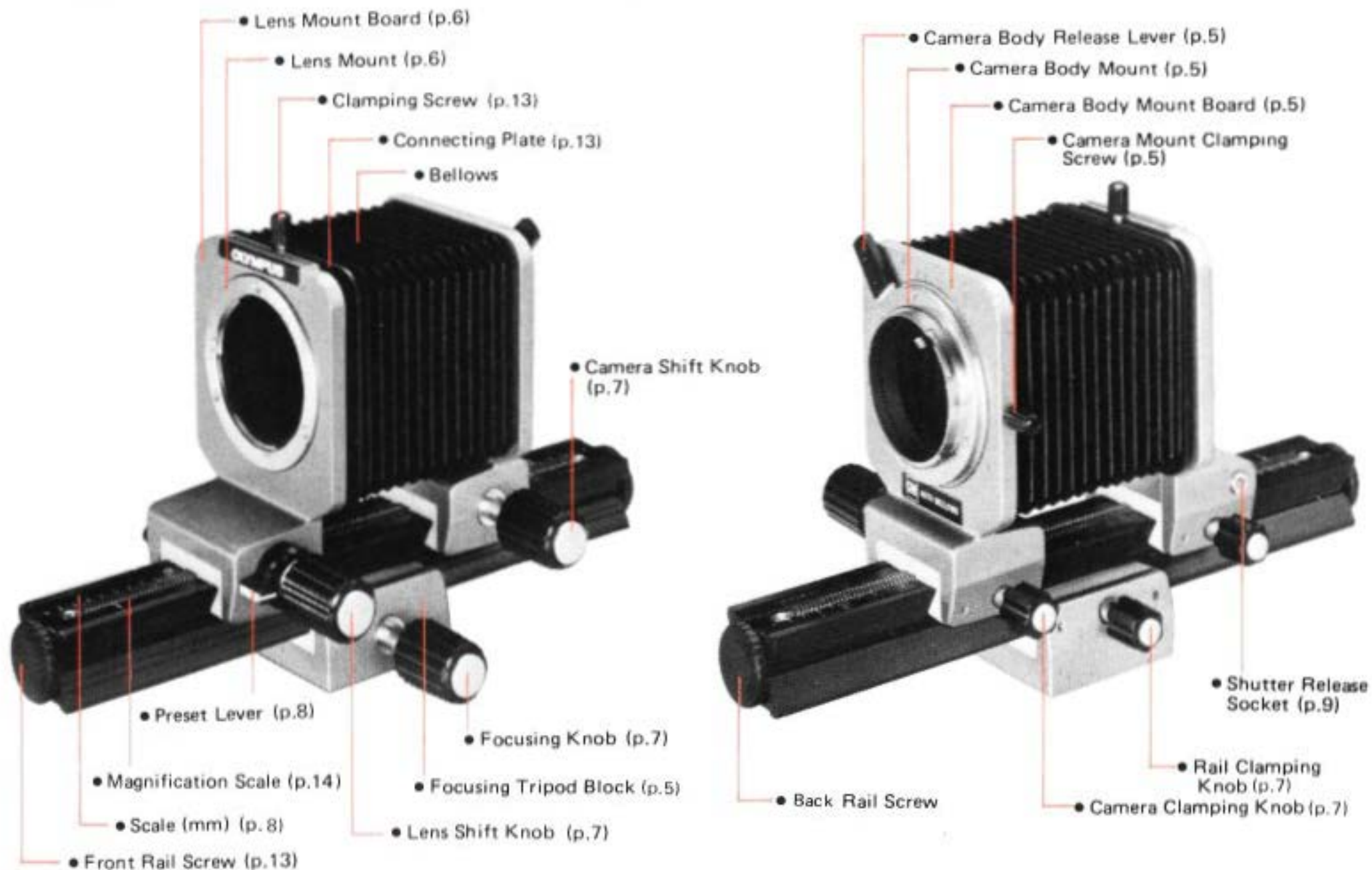

SCALE ON THE RAIL

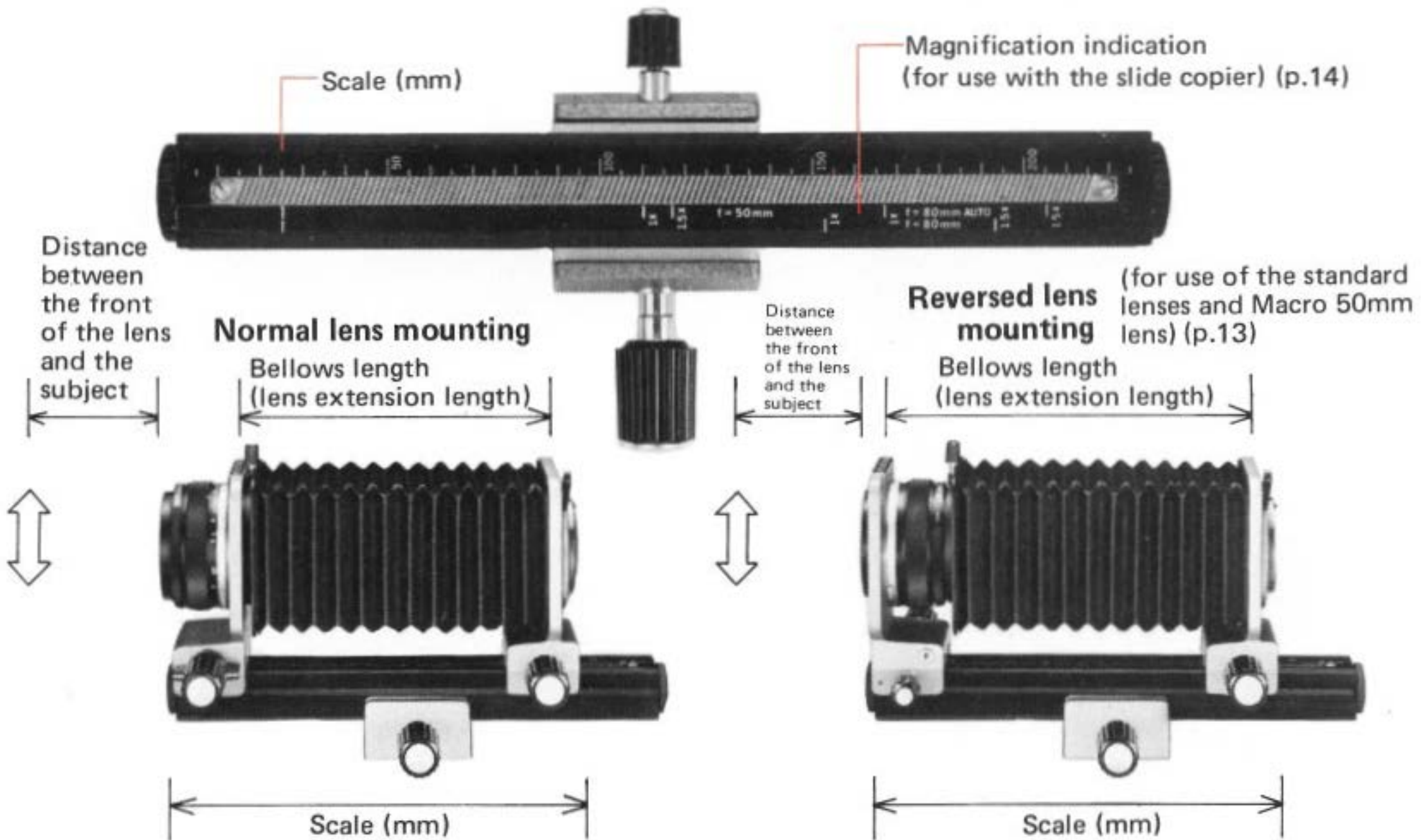

ASSEMBLY



Mount the Auto Bellows on a stable support such as a tripod, copy stand, macro-photo stand, etc.

Either of the two sockets located on the underside of the focusing tripod block can be used for mounting. To select the more suitable socket, however, it is recommended to take into consideration the weight of the camera and lens, bellows length, etc.

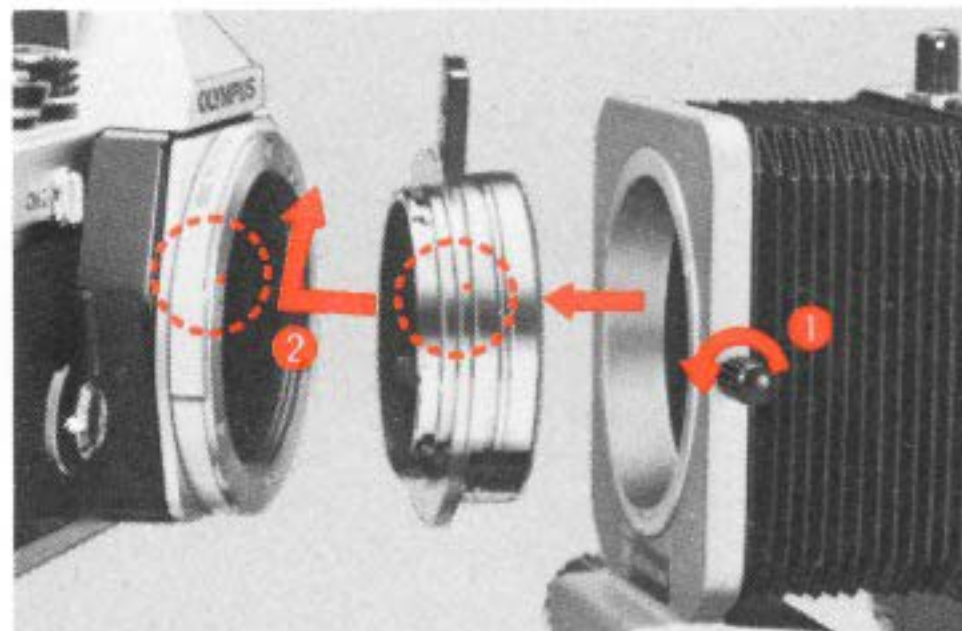
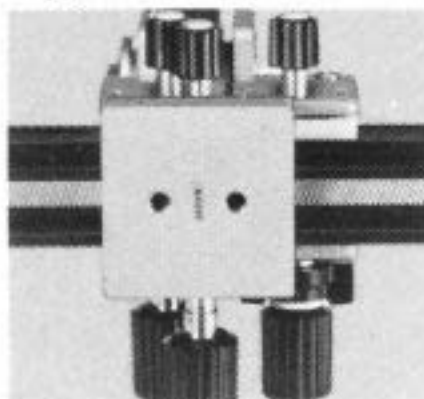

Attach the camera body mount to the camera body.

Aligning red dots, attach the mount to the camera, and rotate the mount until it stops with a positive click. To detach, press the head of camera body release lever, and reverse the mount.

* The camera body should be attached to the bellows before film loading, because the double cable release requires shutter release adjustment without film.

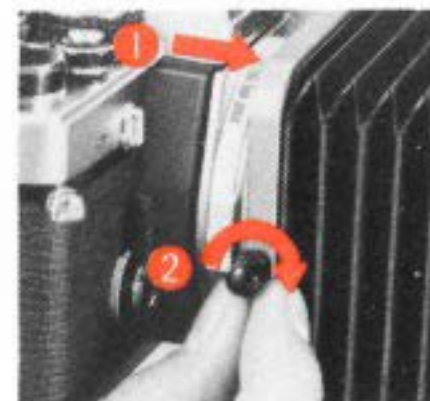



Mount the Lens.

Aligning red dots, turn the lens clockwise in the same manner as normal lens mounting on the camera.

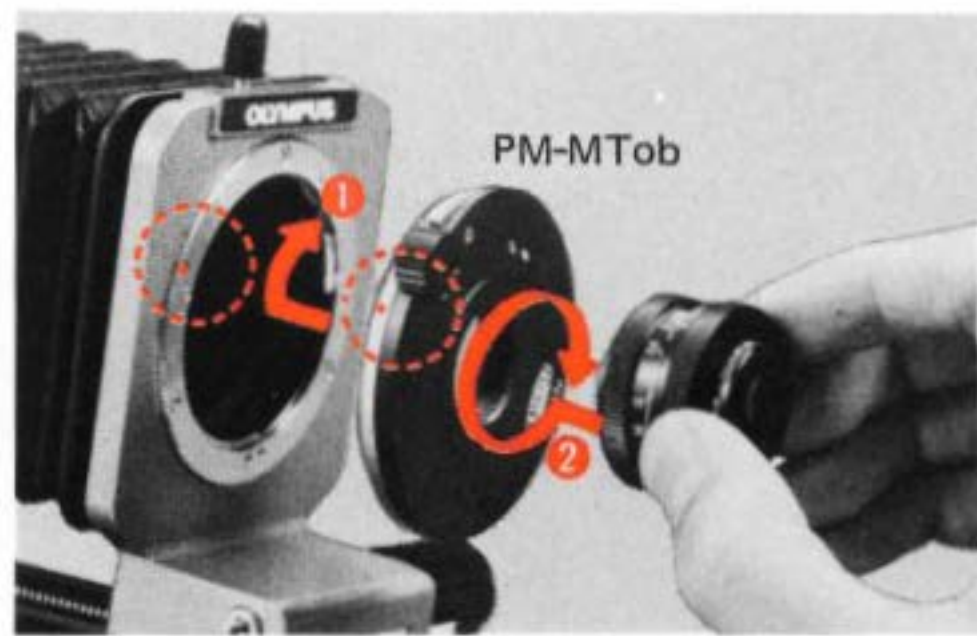

To mount the Macro 20mm or 38mm lens on the Auto Bellows, the Objective Lens Mount PM-MTob is necessary.

First attach the lens mount PM-MTob (optionally available) to the Bellows, then mount the lens.

FOCUSING

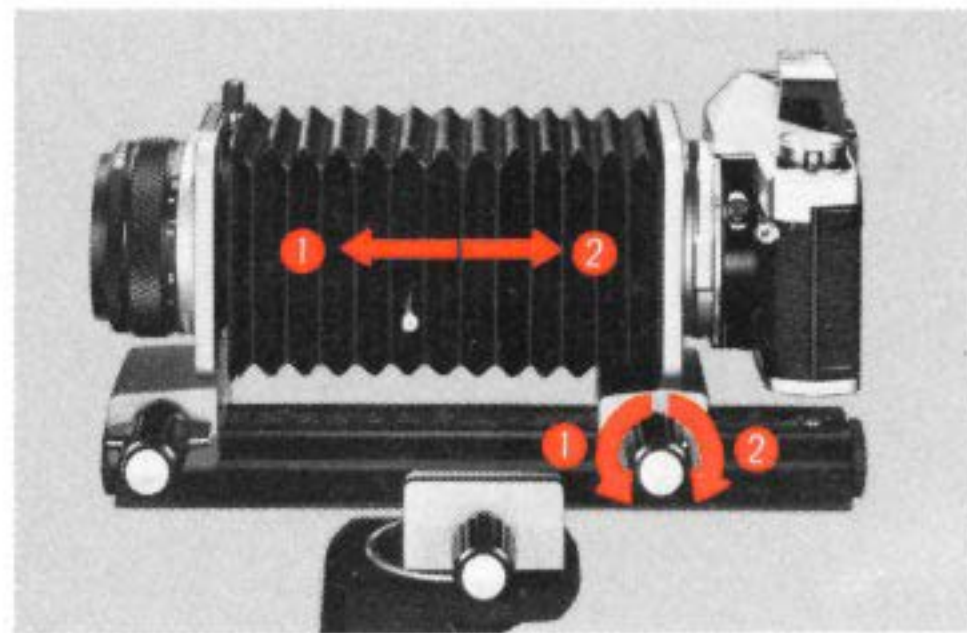
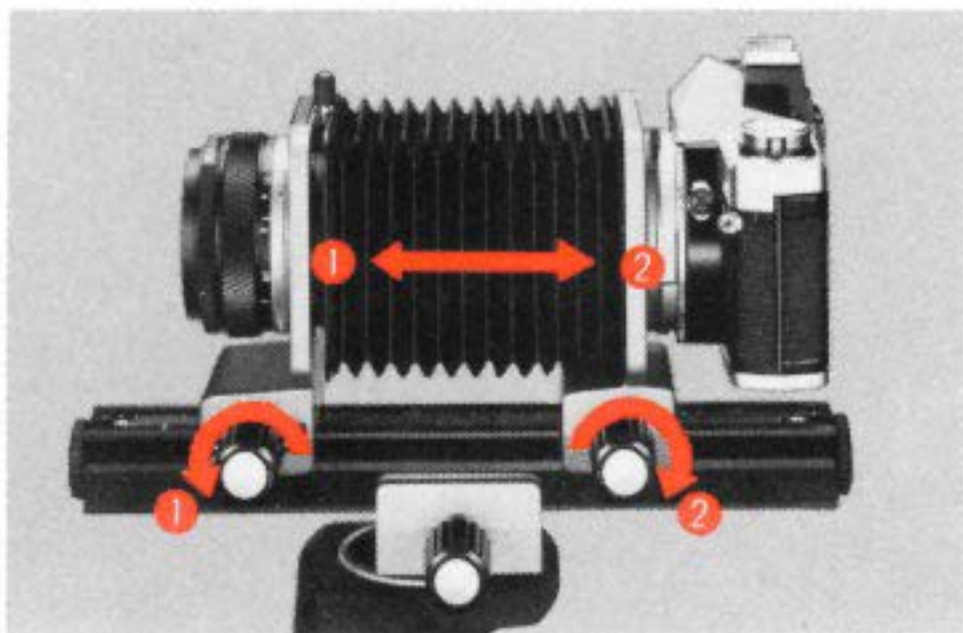

After assembling the Auto Bellows as shown above, determine the distance between the lens ① and body ②, then adjust the lens/subject distance with the focusing knob until the subject is focused.

Do not try to turn any knob while it is clamped. Unlock any knob to be re-adjusted.

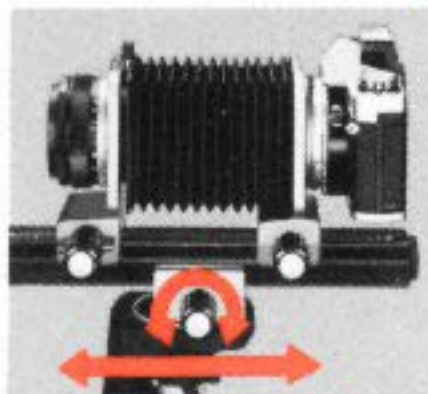

* It is recommended to select a focusing screen (optionally available), most suitable for bright image viewing and easy focusing in accordance with the image magnification as desired.

- (1) If the image is too large as you look through the viewfinder, compress the distance between the lens and camera.
- (2) If the image is too small, extend the distance between the lens and camera.
 - * You can achieve focus adjustment easier by the movement of the camera body with the lens abutting the front rail screw.
- (3) Once the focus is correctly adjusted, clamp the assembly.

USING THE SCALE

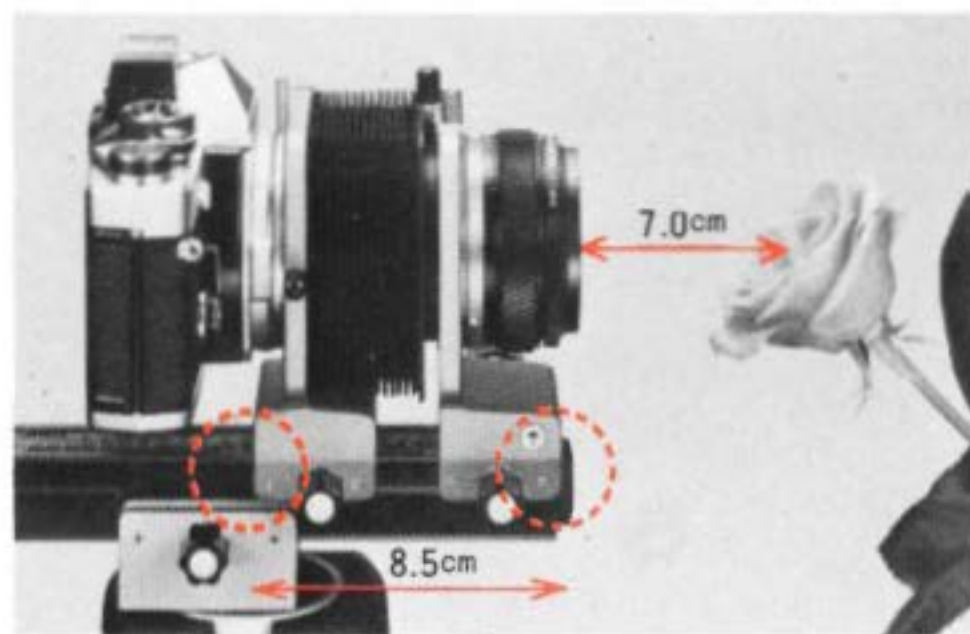

Set the lens mount board to the front rail screw.

Determine the bellows length on the rail by reading the location of the camera body mount board against the mm scale.

For example, if you set the 50mm F1.8 at the end of the rail in normal position (not reversed), and the camera body mount board at 85mm on the scale, and the lens to subject distance at 7cm, you can obtain a magnification 1X from the close-up table. (See p.17-18.)

- * See the close-up tables for various lenses at p.17 and following.
- * Set the focusing ring at ∞ .

EXPOSURE ON THE TTL DIRECT AUTO (OTF) MODE (OM-2)

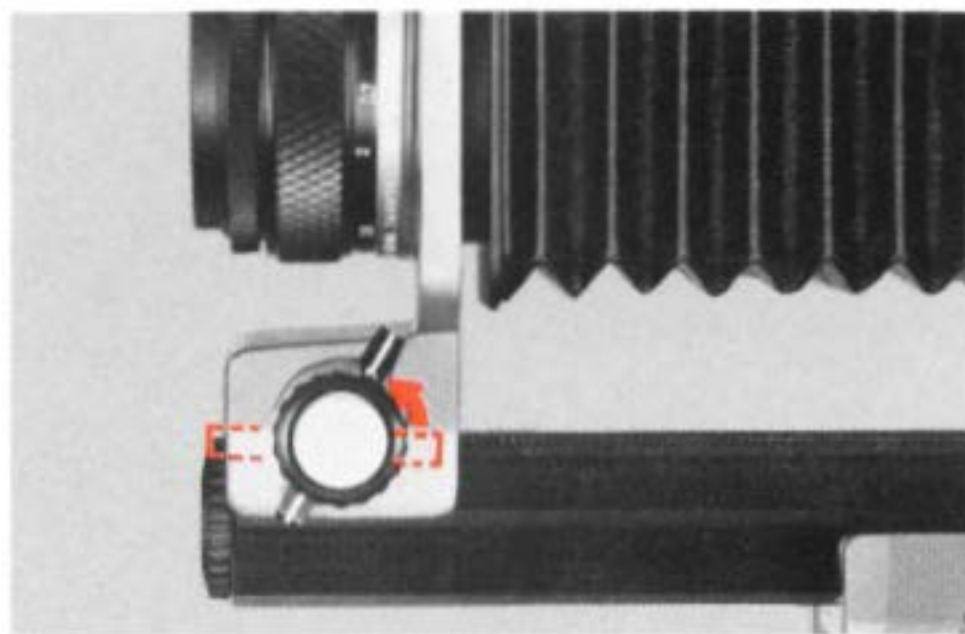

By turning the preset lever into the vertical position, you can check the depth of field at the lens working aperture.

If you set the preset lever in this position before the shutter release (with a single cable release), the double cable release is not needed. (The camera should be set on AUTO.)



- * Although any lens aperture can be used in TTL Direct Auto, F8 or higher lens aperture is recommended.

CONNECTING THE DOUBLE CABLE RELEASE

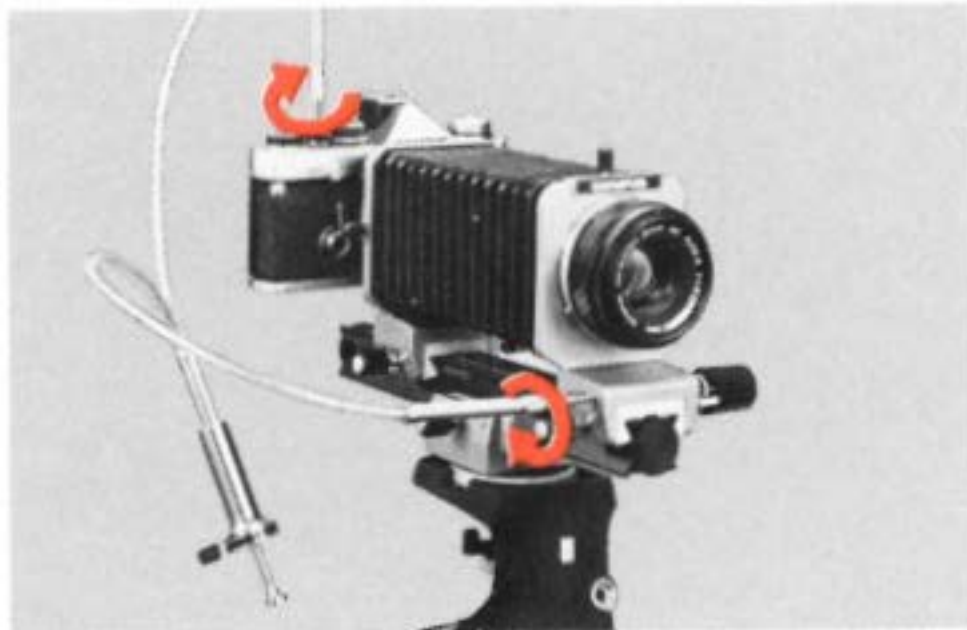

Connect the longer needle to the bellows' shutter release socket, and the shorter needle to the camera's shutter release button.

To test the stop-down movement, release the shutter repeatedly until proper operation is assured in the following steps:

(First ascertain that the selector lever of the OM-2 is set to "MANUAL", then proceed to the steps below for either OM-1 or OM-2.)

- 1) Set the camera shutter speed ring to the "B" (bulb) position.
- 2) Set the lens aperture ring to the minimum aperture.
- 3) Open the camera back.
- 4) Release the shutter slowly by pressing the plunger of the double cable release.

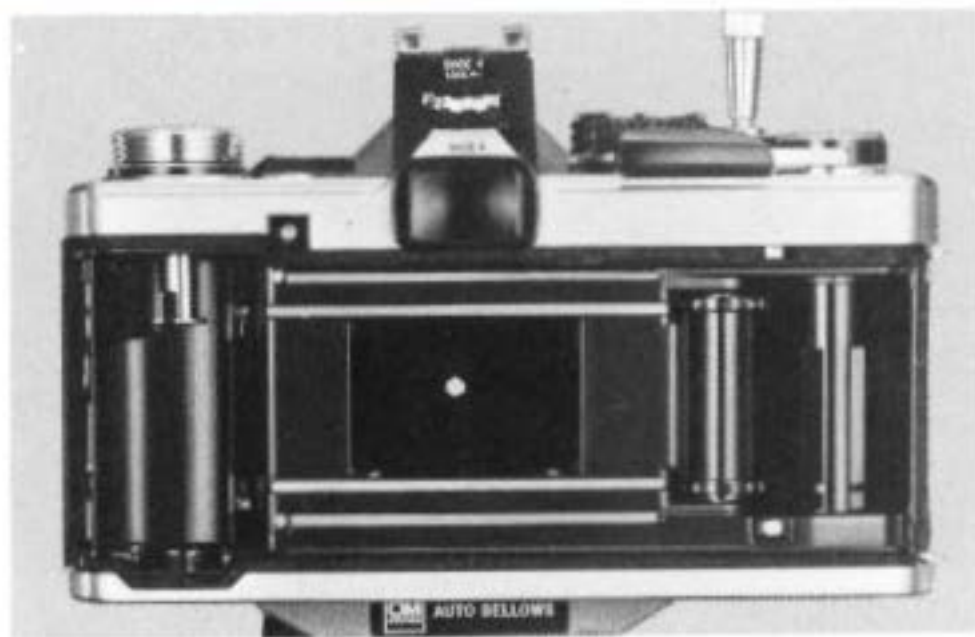

- 5) Look at the diaphragm blades of the lens from backward the camera. As the shutter opens, the diaphragm blades should close to the preselected aperture.
- 6) Apply additional pressure to the plunger. If the diaphragm blades continue to close, make the needle in the bellows longer. Repeat this test until no further movement of the blades can be seen when the plunger is fully depressed.
 - For long time exposures, set the shutter speed ring at "B", and lock the plunger in the depressed position by tightening the clamping screw.

ADJUSTMENT OF THE DOUBLE CABLE RELEASE

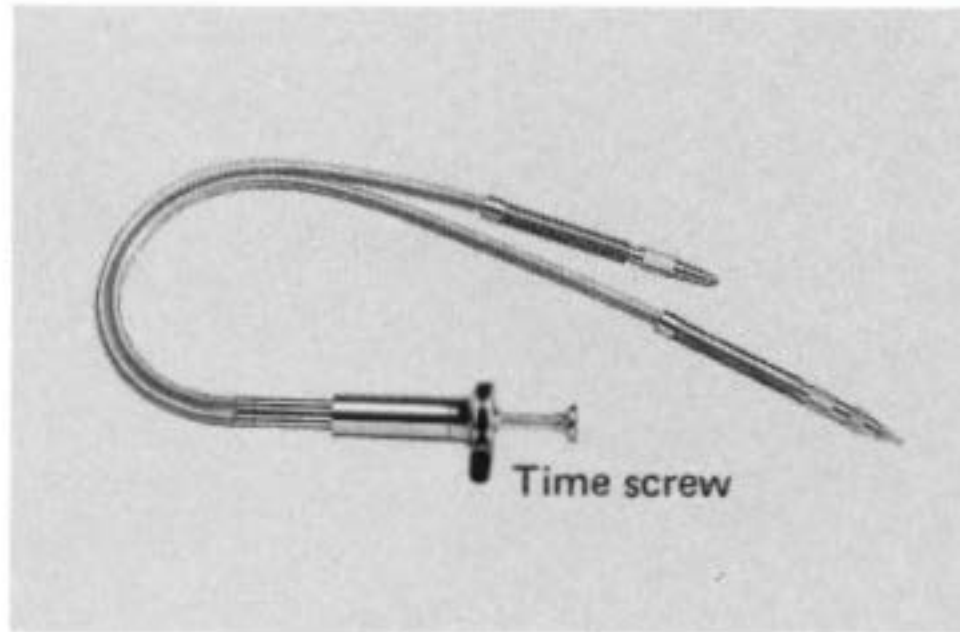

With the double cable release you can synchronize the bellows' stop-down movement with the camera shutter. In order to fully stop down the lens before the shutter is released, the cable needles must be adjusted correctly for synchronization.

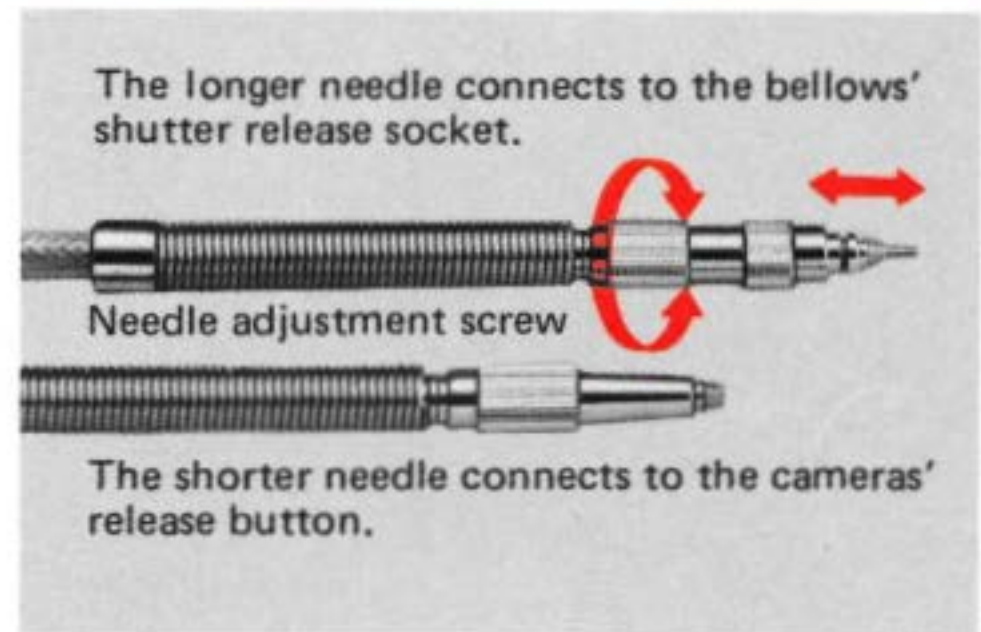

Before connecting this cable to the bellows and camera, loosen the knurled rings, then rotate the needle adjustment screws to adjust the needle lengths as desired. Then clamp the knurled rings.

MANUAL EXPOSURE MODE

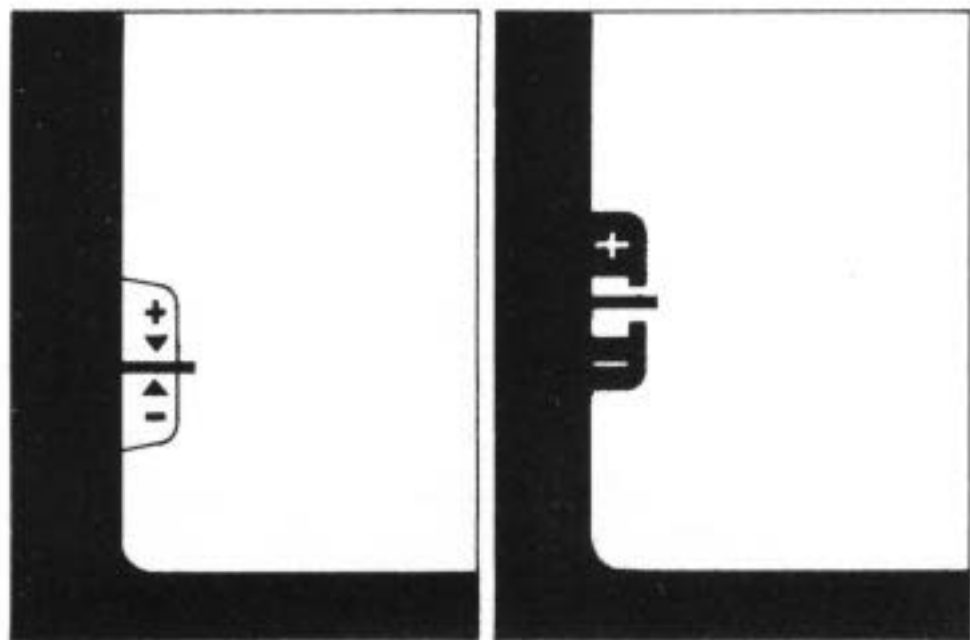

OM-2

OM-1

Turn the aperture ring or the shutter speed ring until the exposure needle centers on the index mark in the viewfinder.



EXPOSURE COMPENSATION

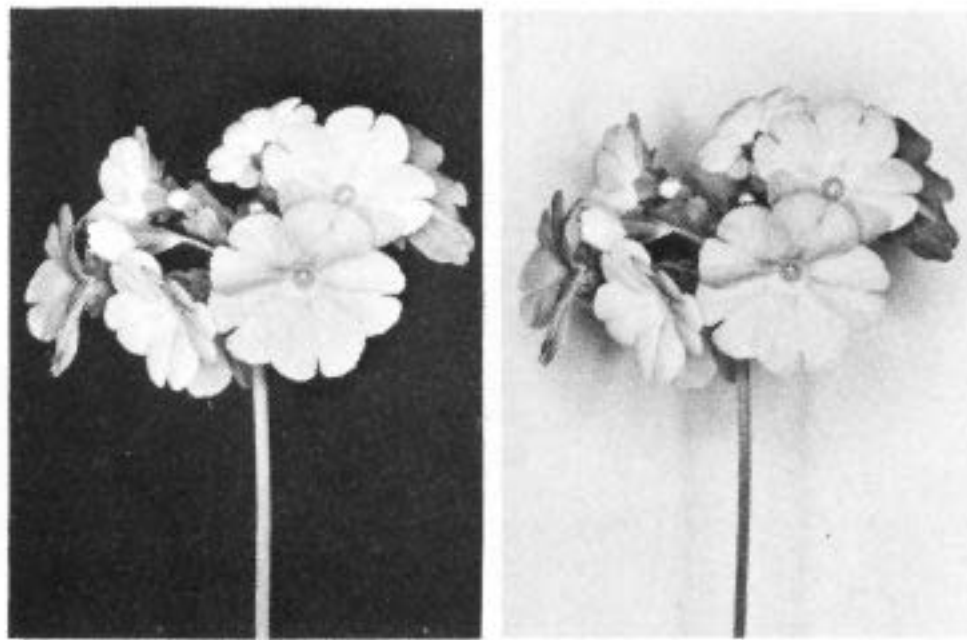

(A bright subject against a dark background) (A dark subject against a bright background)

The exposure can be adjusted by means of the exposure compensation dial of the OM-2 on Auto mode or the exposure needle between the \pm index marks of the OM-1 and OM-2 both in Manual mode.

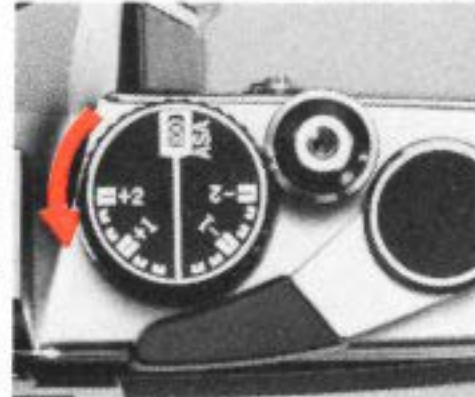
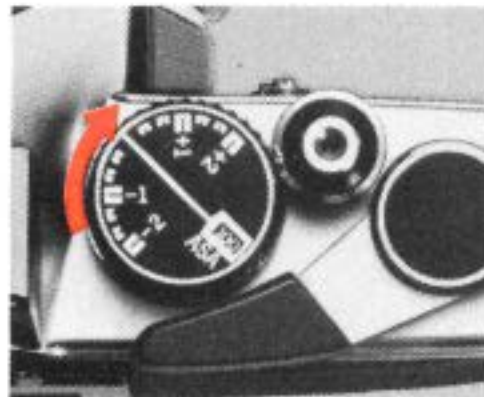

DETERMINING THE SUBJECT AREA AND CHOOSING THE LENS



Determine the subject area before choosing the lens.

List of OM System Macro Lenses with subject areas and magnifications.

Lens	Subject area	Magnification
Zuiko MC Macro 50mm F3.5	$\infty \sim 72 \times 48\text{mm}$ (2.8"×1.9")	$\infty \sim 0.5X$
Zuiko MC 1:1 Macro 80mm F4	$72 \times 48 \sim 18 \times 12\text{mm}$ (2.8"×1.9"~0.7"×0.5")	0.5X ~ 2X
Zuiko MC Macro 135mm F4.5	$\infty \sim 72 \times 48\text{mm}$ (2.8"×1.9")	$\infty \sim 1.5X$
Zuiko MC Macro 38mm F3.5	$20 \times 13 \sim 6 \times 4\text{mm}$ (0.8"×0.5"~0.2"×0.16")	1.8X ~ 6X
Zuiko MC Macro 20mm F3.5	$8 \times 5 \sim 3 \times 2\text{mm}$ (0.3"×0.2"~0.1"×0.08")	4.3X ~ 12X

REVERSING THE LENS

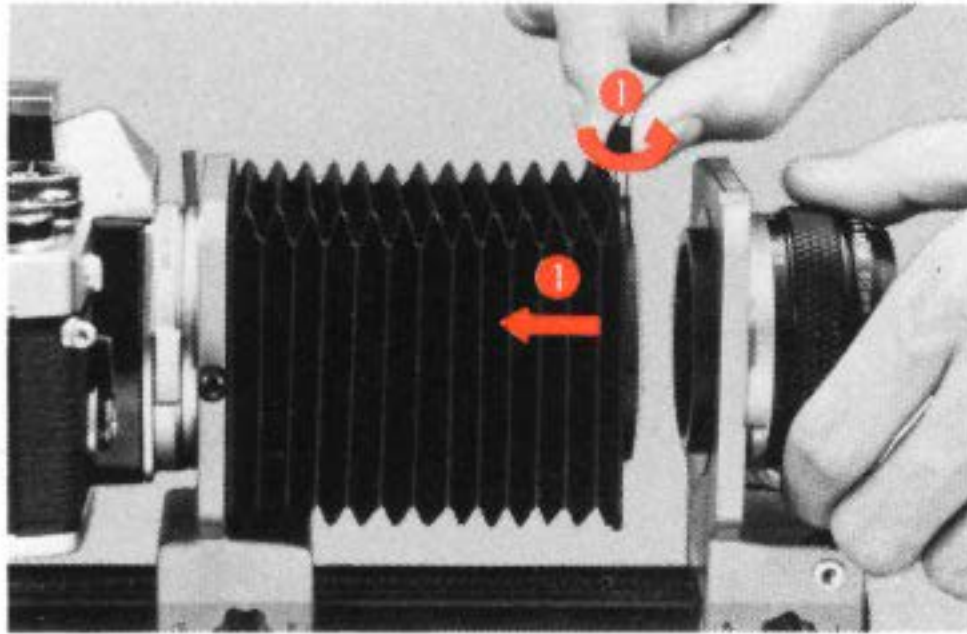

- (1) Loosen the bellows clamping screw and separate the connecting plate from the lens mount board.

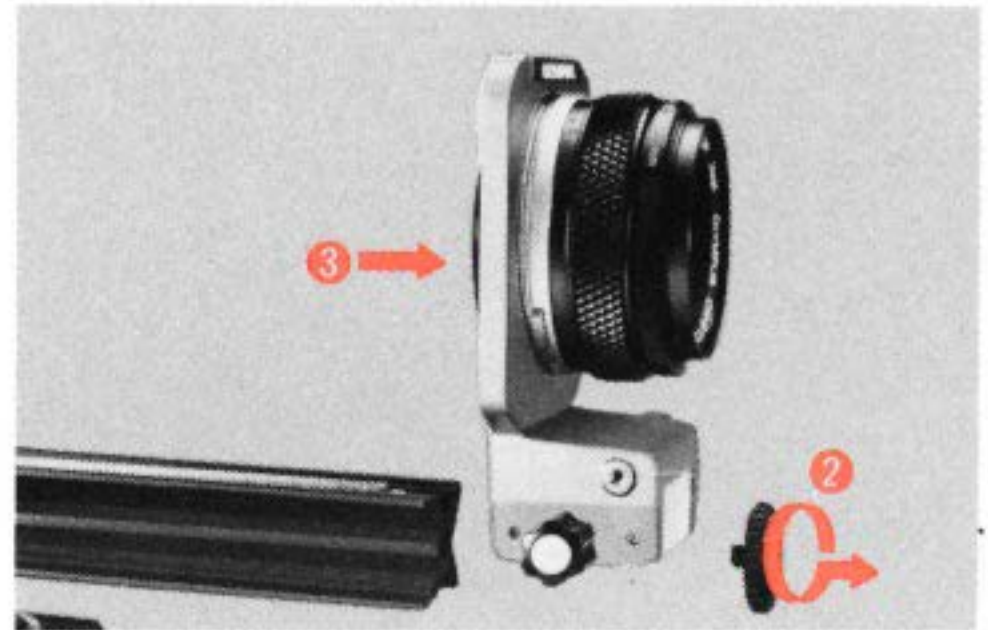

- (2) Loosen the front rail screw.
- (3) Remove the lens and mount board.

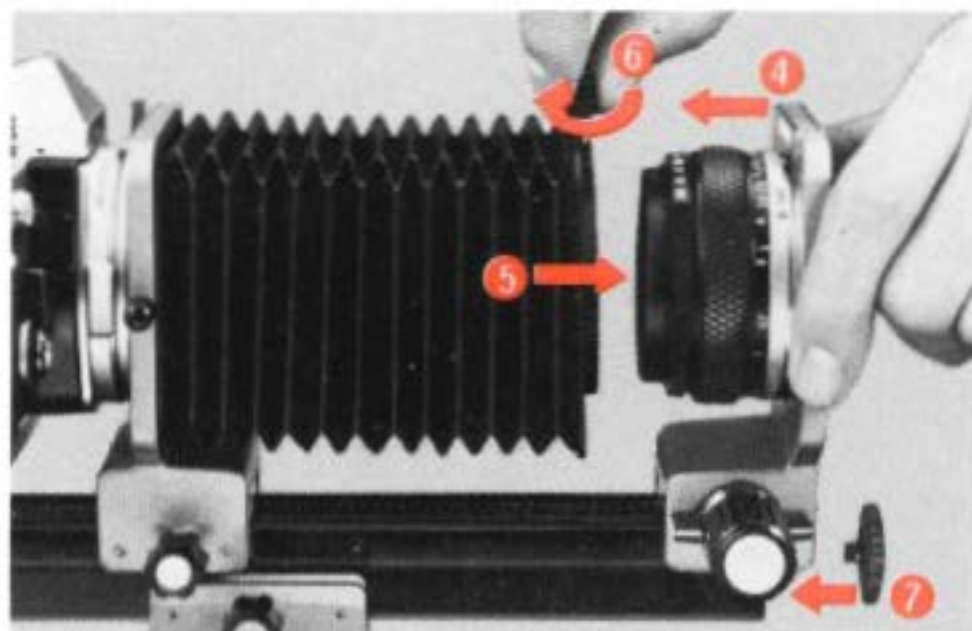

- (4) To reverse the lens, refit the lens mount reversed.
- (5) Insert the lens hood into the connecting plate.
- (6) Tighten the clamping screw.
- (7) Rescrew the front rail screw in place.

* The adapter ring 55 → 49mm is needed to reverse the Macro 55mm F1.2 on the bellows.

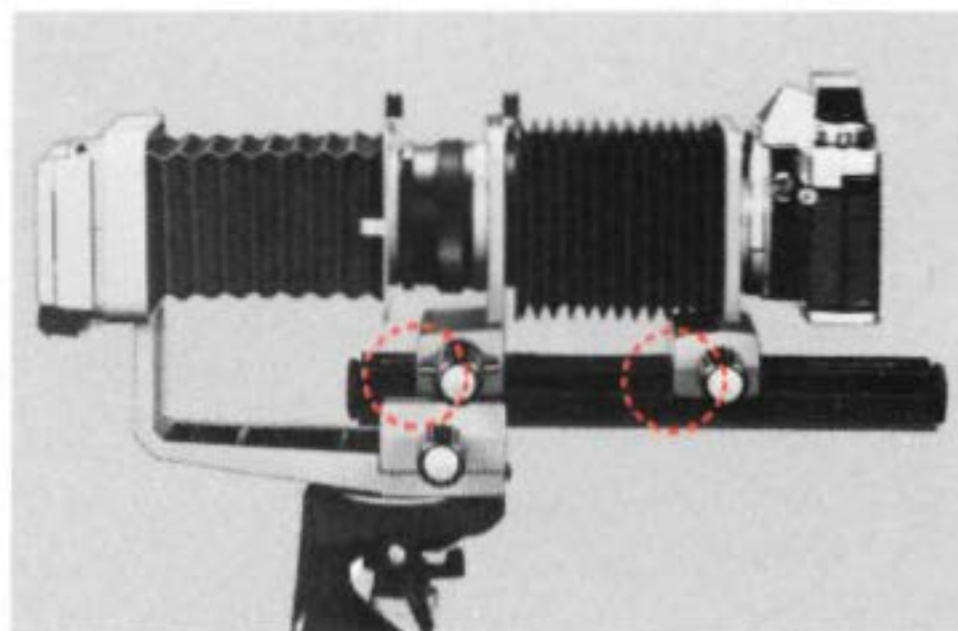

Use a slide copier (optionally available) for duplication.

Move the front of the lens mount board to the orange/white mark on the rail.

Line up the rear of the camera mount board with the 1X mark on the rail for duplicating a 35mm film from a 35mm slide, or with the 1.5X mark for duplicating a 35mm film from a half size slide.

* Use the white indication marks for the 50mm lens and the orange indication marks for the 80mm lens.

LIGHTING



The OM System lighting set is recommended to illuminate the subject.

It is essential to select optimum lighting as bright as possible for macrophotography with the Auto Bellows, because a wide range of exposures can be afforded for accurate focus with ease.

* Tungsten type film is recommended for tungsten light.



Use a T10 Ring Flash 1.

When normal flash units cannot be used effectively because of extremely short working distances between the subject and the lens, the T10 Ring Flash 1 (optional) is recommended for its shadowless illumination and unrivaled lighting performance even at the minimum working distance.



Use an electronic flash.

It is very convenient to use a remote control flash or multi-flash lighting for macrophotography of moving subjects such as living insects, etc.



It is convenient to use a Varimagni Finder for covering low-angle close-up and macrophotography.

CLOSE-UP TABLES

Lens	Lens Position	Subject Area Covered (mm)		Distance												
		Magnification		∞	0.1	0.2	0.3	0.4	0.5	0.6	0.7	0.8	0.9			
					360 × 240	180 × 120	120 × 80	90 × 60	72 × 48	60 × 40	51.4 × 34.3	45 × 30	40 × 26.7			
Professional Method	Zuiko MC Macro 135mm F4.5	Normal	Scale (mm)	98	111.5	125	138.5	152	165.5	179.9	192.5	206	219.5			
			Distance from lens to subject (cm)	∞	144.7	77.2	54.7	43.4	36.7	32.2	28.9	26.5	24.7			
	Zuiko MC 1:1 Macro 80mm F4	Normal	Scale (mm)		69	69.8	77.8	85.8	93.8	101.8	109.7	117.7	125.7	133.7		
			Distance from lens to subject (cm)		93.2	84.7	44.3	31.0	24.4	20.4	17.7	15.8	14.3	13.3		
	Zuiko MC Macro 38mm F3.5	Normal	Scale (mm)													
			Distance from lens to subject (cm)													
	Zuiko MC Macro 20mm F3.5	Normal	Scale (mm)													
			Distance from lens to subject (cm)													
Composite Method	Zuiko MC Macro 50mm F3.5	Normal	Scale (mm)							68	69	74	79	84		
			Distance from lens to subject (cm)							8.8	8.6	7.7	7.0	6.4		
	Zuiko MC 50mm F1.8	Reversed	Scale (mm)													
			Distance from lens to subject (cm)													
	Zuiko MC 50mm F1.4	Normal	Scale (mm)								68	69	74	79	85	
			Distance from lens to subject (cm)									9.4	9.2	8.3	7.6	7.0
	Zuiko MC 50mm F1.2	Reversed	Scale (mm)													
			Distance from lens to subject (cm)													
	Zuiko MC 55mm F1.2	Normal	Scale (mm)									68	72	78	83	89
			Distance from lens to subject (cm)										8.9	8.0	7.0	6.2
	Zuiko MC 55mm F1.2	Reversed	Scale (mm)													
			Distance from lens to subject (cm)													

Zuiko MC Macro 50mm F3.5 is recommended for use at the 0.5X position.

	36	30	25.7	22.5	20	18	16.4	15	13.8	12.9	12	10.3	9	8	7.2	6.5	6	5.5	5.1	4.8	4.5	4	3.6	3.3	3.0		
	×	×	×	×	×	×	×	×	×	×	×	×	×	×	×	×	×	×	×	×	×	×	×	×	×	×	
	24	20	17.1	15	13.3	12	10.9	10	9.2	8.6	8	6.9	6	5.3	4.8	4.4	4	3.7	3.4	3.2	3.0	2.7	2.4	2.2	2.0		
	1.0	1.2	1.4	1.6	1.8	2.0	2.2	2.4	2.6	2.8	3.0	3.5	4.0	4.5	5.0	5.5	6.0	6.5	7.0	7.5	8.0	9.0	10.0	11.0	12.0		
231+7																											
23.1																											
141.7 157.7 173.7 189.6 205.6 221.6 231.0+(7.8)																											
12.4 11.1 10.2 9.4 8.8 8.4 8.1																											
68 75 83 90 98 106 113 132 151 170 189 208 227 231																											
4.6 4.4 4.3 4.1 4.0 3.9 3.8 3.6 3.5 3.4 3.3 3.2 3.2 3.2																											
68 73 83 93 103 118 123 133 143 163 183 203 223 231																											
2.1 2.1 2.1 2.0 2.0 2.0 2.0 1.9 1.9 1.9 1.9 1.8 1.8 1.8																											
84																											
6.4																											
102 112 123 134 144 155 166 177 187 198 209 230																											
6.2 5.3 4.7 4.2 3.8 3.5 3.3 3.1 2.9 2.8 2.6 2.4																											
85																											
7.0																											
78 89 99 109 120 130 140 151 161 171 187 223 231																											
7.8 7.2 6.7 6.3 6.1 5.8 5.6 5.5 5.3 5.2 4.9 4.8 4.7																											
85																											
6.0																											
73 74 84 95 105 115 126 136 146 157 167 193 219 231																											
7.8 7.8 7.2 6.7 6.3 6.0 5.8 5.6 5.4 5.3 5.2 4.9 4.8 4.7																											
89																											
5.6																											
89 93 104 115 126 137 149 160 171 182 211 231																											
7.7 7.5 7.0 6.6 6.3 6.0 5.8 5.6 5.5 5.3 5.1 4.9																											

(Set the focusing ring at ∞.)

(Set the focusing ring at closest distance.)

(Set the focusing ring at ∞.)

(Use the adapter ring 55 → 49mm.)

CLOSE-UP TABLES

See the following close-up tables for use of the various macro lenses mounted on the Auto Bellows in the normal position.

Notes on some terms used in the tables:

- Magnification

The magnification implies the ratio image size/subject size.

- Exposure factor

For macrophotography with flash lighting in conjunction with the OM-1 and OM-2 on MANUAL mode, you must calculate an exposure factor to compensate for any loss of light due to close-up exposure greater than normal, because the higher the magnification, the larger the lens extension, and the intensity of the light that falls on the film decreases, which must be compensated for by the increase of the exposure.

An exposure factor can be obtained in the following equation:

$$\text{Exposure factor} = (1 + \text{Magnification})^2$$

where, if the magnification 1:1, an exposure factor is 4 and therefore, in order to prevent underexposure macrophotographs, the exposure must be increased by 4 times (2 stops).

For instance, an electronic flash NG16 is used at a distance of 1m from the subject, the lens aperture is F16. If the camera is brought nearer the subject, leaving the flash in the original position, until the magnification becomes 1:1, the lens aperture must be opened by 2 stops up to F8.

Zuiko MC Macro 50mm F3.5

(No Auto Bellows. Bold lines indicate the optimum application range of this lens.)

	Magnif. index engraved on the lens	Magnif.	Distance from film to subject	Distance from lens to subject	Subject area covered	Exposure factor
With Macro 50mm F3.5 only	1:10	0.10×	62.2cm	53.0cm	240 × 360mm	1.2×
	1:8	0.13×	51.9	42.6	192 × 288	1.3×
	1:7	0.14×	47.5	38.1	168 × 252	1.3×
	1:6	0.17×	41.1	31.6	144 × 216	1.4×
	1:5	0.20×	36.7	27.0	120 × 180	1.4×
	1:4	0.25×	31.7	21.8	90 × 144	1.6×
	1:3	0.33×	27.0	16.6	72 × 108	1.8×
	1:2.5	0.40×	24.7	14.0	60 × 90	2.0×
With Macro 50mm plus Close up 49mm f = 40mm	1:3	0.47×	22.5	11.6	51 × 77	2.2×
	1:2.5	0.60×	20.7	9.1	40 × 60	2.6×
	1:2	0.64×	20.4	8.7	38 × 56	2.7×

For the ranges outside the bold lines, Zuiko MC 1:1 Macro 80mm F3.5 is specially recommended.

Zuiko MC 1:1 Macro 80mm F4

(Bold lines indicate the optimum application range of this lens.)

Mag. nif.	Bellows length	Lens extension distance on scale	Distance from film to subject	Distance from lens to subject	Subject area covered	Exposure factor
0.09	36.0mm	69.0mm	104.0cm	93.2cm		11.2×
0.1	36.8	69.8	95.7	84.7	240.0×360.0mm	11.2×
0.2	44.8	77.8	56.5	44.3	120.0×180.0	11.4×
0.3	52.8	85.8	44.0	31.0	80.0×120.0	11.7×
0.4	60.8	93.8	38.2	24.4	60.0×90.0	22.0×
0.5	68.8	101.8	35.0	20.4	48.0×72.0	22.3×
0.6	76.7	109.7	33.1	17.7	40.0×60.0	22.6×
0.7	84.7	117.7	32.0	15.8	34.3×51.4	22.9×
0.8	92.7	125.7	31.4	14.4	30.0×45.0	33.2×
0.9	100.7	133.7	31.1	13.3	26.7×40.0	33.6×
1.0	108.7	141.7	31.0	12.4	24.0×36.0	44.0×
1.1	116.7	149.7	31.1	11.7	21.8×37.7	44.4×
1.2	124.7	157.7	31.2	11.1	20.0×30.0	44.8×
1.4	140.7	173.7	31.9	10.2	17.1×25.7	55.8×
1.6	156.6	189.6	32.8	9.4	15.0×22.5	66.8×
1.8	172.6	205.6	33.8	8.8	13.3×20.0	77.8×
2.0	188.6	221.6	35.0	8.4	12.0×18.0	9.0×
2.1	196.6	229.6	35.5	8.2	11.4×17.0	9.6×
2.12	198.0	231.0	35.7	8.2	11.3×17.0	9.7×
2.22	198.0+78.0mm	231.0+7.8mm	36.2	8.1	10.8×16.3	10.4×

For better results, Macro 50mm F3.5 is recommended for image magnifications 0.4 and lower, and Macro 38mm F3.5 for image magnifications 2.2 and higher.

Zuiko MC Macro 135mm F4.5

(Bold lines indicate the optimum application range of this lens.)

Mag. nif.	Bellows length	Lens extension distance on scale	Distance from film to subject	Distance from lens to subject	Subject area covered	Exposure factor
∞	65.0 mm	98.0mm	∞	∞		1.00×
0.1	78.5	111.5	161.8cm	144.7cm	240.0×360.0mm	1.21×
0.2	92.0	125.0	95.7	77.2	120.0×180.0	1.44×
0.3	105.5	138.5	74.5	54.7	80.0×120.0	1.69×
0.4	119.0	152.0	64.6	43.4	60.0×90.0	1.96×
0.5	132.5	165.5	59.2	36.7	48.0×72.0	2.25×
0.6	146.0	179.9	56.1	32.2	40.0×60.0	2.56×
0.7	159.5	192.5	54.2	28.9	34.3×51.4	2.89×
0.8	173.0	206.0	53.1	26.5	30.0×45.0	3.24×
0.9	186.5	219.5	52.6	24.7	26.7×40.0	3.61×
0.985	198.0	231.0	52.5	23.4	35.5×23.6	3.94×
1.0	198.0+(2)	231.0+(2)	52.5	23.1	36.0×24.0	4.00×
1.04	198.0+(7)	231.0+(7)	52.5	22.6	37.5×25.0	4.16×

Zuiko MC Macro 38mm F3.5

(Bold lines indicate the optimum application range of this lens.)

Magnif.	Bellows length	Lens extension distance on scale	Distance from film to subject	Distance from lens to subject	Subject area covered	Exposure factor
1.8	3.6cm	68mm	16.2cm	4.6cm	13.2×19.8mm	7.9×
2.0	4.2	75	16.7	4.4	12.0×18.0	9.0×
2.2	5.0	83	17.3	4.3	10.9×16.4	10.2×
2.4	5.8	90	17.9	4.1	10.0×15.0	11.6×
2.6	6.5	98	18.5	4.0	9.2×13.8	13.0×
2.8	7.3	106	19.2	3.9	8.6×12.9	14.4×
3.0	8.0	113	19.9	3.8	8.0×12.0	16.0×
3.5	9.9	132	21.6	3.6	8.9×10.3	20.3×
4.0	11.8	151	23.3	3.5	6.0×9.0	25.0×
4.5	13.7	170	25.1	3.4	6.3×8.0	30.3×
5.0	15.6	189	27.0	3.3	5.8×7.2	36.0×
5.5	17.5	208	28.8	3.2	4.4×6.5	42.3×
6.0	19.4	227	30.6	3.2	4.0×6.0	49.0×
6.1	19.8	231	31.0	3.2	3.9×5.9	50.4×

Zuiko MC Macro 20mm F3.5

(Bold lines indicate the optimum application range of this lens.)

Magnif.	Bellows length	Lens extension distance on scale	Distance from film to subject	Distance from lens to subject	Subject area covered	Exposure factor
4.3	3.6cm	68mm	12.9cm	2.1cm	5.6×8.4mm	27.9×
4.5	4.0	73	13.3	2.1	5.3×8.0	30.3×
5.0	5.0	83	14.3	2.1	4.8×7.2	36.0×
5.5	6.0	93	15.2	2.0	4.4×6.5	42.3×
6.0	7.0	103	16.2	2.0	4.0×6.0	49.0×
6.5	8.0	113	17.2	2.0	3.7×5.5	56.3×
7.0	9.0	123	18.2	1.9	3.4×5.1	64.0×
7.5	10.0	133	19.2	1.9	3.2×4.8	72.3×
8.0	11.0	143	20.1	1.9	3.0×4.5	81.0×
8.5	12.0	153	21.1	1.9	2.8×4.2	90.3×
9.0	13.0	163	22.1	1.9	2.7×4.0	100.0×
9.5	14.0	173	23.1	1.9	2.5×3.8	110.3×
10.0	15.0	183	24.1	1.9	2.4×3.6	121.0×
10.5	16.0	193	25.1	1.8	2.3×3.4	132.3×
11.0	17.0	203	26.1	1.8	2.2×3.3	144.0×
11.5	18.0	213	27.1	1.8	2.1×3.1	156.3×
12.0	19.0	223	28.1	1.8	2.0×3.0	169.0×
12.4	19.8	231	28.9	1.8	1.9×2.9	179.2×

SPECIFICATIONS

Camera: OLYMPUS OM System Camera Bodies

Lens Mount: Olympus OM-Mount bayonet (rotation angle 70°).

Lenses: OM System Zuiko lenses

MC Macro 135mm F4.5, MC 1:1 Macro 80mm F4, MC Macro 38mm F3.5, MC Macro 20mm F3.5 (MC Macro 50mm F3.5; Standard 50mm F1.8, 50mm F1.4, 55mm F1.2)

Bellows Extension Range:

36mm–198mm (1-3/8" – 7-3/4")
(lens in normal position).

56mm–218mm (2-3/16" – 8-9/16")
(lens in reversed position).

Graduated focusing rail is 180mm
(7-1/16") long.

Focusing: By focusing knob with locking device on the focusing stage.

Automatic Stop-Down Exposure: Diaphragm linked with shutter by double cable release.

Preset Lever: Stops down diaphragm to preset aperture for previewing depth of field.

Reverse Lens Mounting: Lens and camera mount boards, detachable for quick reversing of lens.

Tripod Mounting: Two threaded sockets for mounting on a tripod or on the Macrophoto Stand B Adapter.

Focusing Stage: With bellows removed, focusing rail can be mounted.

Dimensions: W 74mm (2-15/16") × H 132mm (5-3/16") × D 240mm (9-3/8").

Weight: 930g

CARE FOR USE AND MAINTENANCE



- (1) Be sure to clamp each knob before starting operations in order to avoid unnecessary movements of the assembly during the operation.
- (2) Avoid moving each component unless it is unclamped.
- (3) To use the camera body in the vertical position, move the camera body mount back to the extreme end of the rail.
- (4) After use in high temperature and humidity, wipe the instrument completely.
- (5) After quick transferal from a low to a high temperature place, wipe it completely to prevent it from dewing.
- (6) It is necessary to stop down the lens aperture manually for exposure reading after focusing through the fully opened aperture.
- (7) It is convenient to use the focusing knob for focusing adjustment, while the lens shift knob and camera shift knob for magnification adjustment.
- (8) If the bellows is used in the most compressed condition, it may sometimes cause cutting in the periphery of a picture.



OLYMPUS[®]

OLYMPUS OPTICAL CO.,LTD.

San-Ei Building, 22-2, Nishi Shinjuku 1-chome, Shinjuku-ku, Tokyo, Japan. Tel. 03-340-2211

OLYMPUS CAMERA CORPORATION

Crossways Park, Woodbury, New York 11797, U.S.A. Tel. 516-364-3000

OLYMPUS OPTICAL CO.(EUROPA) GMBH.

Postfach 104908, Wepdenstrasse 14-16, 2 Hamburg 1, West Germany. Tel. 040-23773-0

OLYMPUS OPTICAL CO.(U.K.) LTD.

2-8 Honduras Street, London EC1Y 0TX, England. Tel. 01-253-2772

PRINTED IN JAPAN 1281-2MT